

# ISOTHERM-MULTICON TRAVELLER

SETTING UP INSTRUCTIONS FOR

## DATA INTERFACE de G3LIV



## Welcome to the World of PSK-31.

Thank you for purchasing this **ISOTERM**. I hope it will give you hours of unbelievable PSK31 Dx.

The **ISOTERM** as its name implies is designed to reduce the chance of RF and Earth type feedback problems. Which can result in unacceptable signals being radiated. There are no physical connections between the Computer and Rig grounds. This helps reduce any possible earth loop problems.

Both Audio paths between Computer and Rig are Transformer coupled, whilst the PTT is coupled through a Miniture DIL Relay.

ALL leads in and out of the **ISOTERMs** are screened, however it is still good practice to keep leads as short as possible. Good practice like keeping leads apart from antenna and other computer I/O cables can only help in obtaining a good clean signal on PSK-31.

I won't go into setting up the transmitter parameters as these are well covered in the **HELP FILES** on the popular software programmes. **Including the supplied ones.** But you must make sure that you go to **SET UP and designate COM's port and sample rate**, enter 11025 to start with if you are requested. **PRINT OUT THE HELP FILES ON THE SOFTWARE YOU DECIDE TO USE.**

You will on inspection of the interface see that there are cables coming out from both sides of the **ISOTERM**. One side has 2-3.5mm Jack Plugs on a 3 core screened cable. One with a **marker band** on it. This should be inserted into **LINE IN on the SOUNDBOARD**. It carries the **AUDIO from your RX** through the **ISOTERM** to the Soundboard and drives the WATERFALL DISPLAY.

The other 3.5mm Jack should be inserted into **LINE OUT on the SOUNDBOARD**. This carries the **AUDIO OUTPUT of the SOUNDBOARD through the ISOTERM** to the rigs Mike or alternative mike inputs on rear of rig. The Rig side cable is a replaceable one so as to give choice of rig type used. This is a 6 Pin Mini Din socket. (Pin out is shown later )

**AUDIO OUTPUT** into the Soundboards **LINE IN**, and used in conjunction with the **SOUNDBOARDs LINE IN** slider and the interfaces **FRONT** panel control thes will allow correct level of drive to be presented to the **WATERFALL..** The **ISOTERM MULTICONS DATA** also has a **Transmit level attenuator control** on the **FRONT** panel and should be set to suit your individual TX drive requirements.

**Power output with a standard 100 watt SSB rig should be set 35/40 Watts MAX.**

**This is because data modes are 100% Duty cycle. Unlike SSB.**

The other lead has a 9 pin D connector fitted. This should be inserted in COM's port you have selected in the software, this 9 pin D lead is the PTT switching. **The ISOTERM is wired for RTS.**

A good strating point is to set BOTH the front panel controls to MID SCALE. Then set up the soundboard Sliders. Then the **FRONT** panel controls will give a +/- variation of both Waterfall and Powwere output.

There are 2 Indicator LEDs on the front panel

GREEN = RECEIVE MODE

RED= TRANSMIT MODE, these should change status when TRANSMIT is selected in the software.

I have enclosed a CD with various popular programs, Please use **DIGIPAN**, first. I am more experianced in these programs and more able

To help you should you have problems at first setting up.

**On the soundcards control panel, The VOLUME slider controls the amount of signal being fed to the Rig Via the ISOTERMS attenuator And the AUX slider the amount of Receiver Audio driving the Soundboard input. A little play with these controls will make there function obvious.**

**On the soundcards control panel, The VOLUME slider controls the amount of signal being fed to the Rig Via the ISOTERMS attenuator And the AUX slider the amount of Receiver Audio driving the Soundboard input. A little play with these controls will make there function obvious.**

## ISOTERM DATA SETUP INSTRUCTIONS.

On the opposite end of the **ISOTERMs** to the cables just discussed is a second multi core screened cable. This is an interchangeable one in the case of the **Multicon** units and may only be 2 core on FT-847 and some other Yaesu transceivers. This is prewired to suit your selected rig at purchase.

Although the mike input socket on the front of the rig can be used to pick up PTT and Mike input. I prefer to use the REAR panel I/Os these are tidier and designed for the job. Don't forget that the mike should be switched off or unplugged during PSK-31 transmissions. Unless as on some rigs a rear ACC socket can, if correct pin is selected the Mike is disconnected automatically. USB is the sideband used and do not have Speech Processors switched on.

### COMPUTER CONNECTIONS

**YELLOW 3.5mm Jack plug with marker fitted into LINE IN of SOUNDBOARD.**

**RED 3.5mm Jack plug (no marker) into LINE OUT of SOUNDBOARD.**

**BLACK 9 Pin D Socket to COM's port as selected in software.**

Transceivers connection colours are really to varied to explain

if you require information on this please just email me.

I hope I have covered most of the necessary details in getting the **ISOTERMs** successfully installed

If you feel any point have not been covered sufficiently please let me know and I will modify instructions if necessary. So if you have any problem with getting this going.

PSK-31 is a wonderful new mode and requires only quite modest power. Most stations seem to run only 25 to 50 watts. The most popular freq. used at this time is 14070 kHz all of the programs have a waterfall indication of signals that make tuning a simple process.

I would suggest connecting one lead at a time, and checking its function as you go. RX audio would seem the first choice. Followed by PTT then Audio to mike input would see a logical progression.

If you feel happy enough to report on my interface, please go to  
[www.eham.net/reviews/detail/1456](http://www.eham.net/reviews/detail/1456)

You will see reviews of my interface under PSK ISOTERM.  
Add your comments if you wish.

Email me on [johnny@melvin.com](mailto:johnny@melvin.com) or you can check out my web page on [www.g3liv.co.uk](http://www.g3liv.co.uk)

Or phone me if you prefer on 0191 2843028

Mr Johnny Melvin G3LIV.  
2 Salters Court  
Gosforth  
Newcastle upon Tyne, NE3 5BH.

## ADDITIONAL NOTES FOR MULTICON UNIT

All **ISOTERMS** are suitable for most of the modes generally now available.  
**PSK31-SSTV-RTTY-WSJT-WSPR** just to name a few.  
ALL Isoterms now have interchangeable rig cables.

All Multicons have relay control of PTT.

Both TRANSMIT and RECEIVE level can be controlled from the FRONT panel controls.

The computer input side cable is the now standard 3 core individually screened with 2 – 3.5mm Jacks for LINE IN-LINE OUT, and the 9 Pin D for Coms port connection.  
I good quality RS232 to USB adaptor lead can be used if no COMs port is available.

The rig out connections are brought to a 6 Pin mini Din.  
Replacement leads are available to allow other rigs to be controlled should you require.

If you decide to construct your own replacement cables,  
the 6 pin mini pin outs are as follows.

- Pin 1 Tx Tones out, from computer. BROWN
- Pin 2 Rig Grounds. ( to ALL screens ) RED & SCREENS SHORTED
- Pin 3 PTT Relay contact. This shorts to ground on command from Coms port ORANGE
- Pin 4 No connection.
- Pin 5 RX Audio IN from Transceiver.This ends up at LINE IN Jack. GREEN
- Pin 6 No connection.

Only screened cable should be used in all cases.

Although **KENWOOD** and **ICOM 706** rigs use the same 13 Pin Din Plug.  
The wiring **IS NOT** the same. If a KENWOOD wired plug is inserted  
into a ICOM 706 this will cause THE INTERNAL FUSE TO RUPTURE.

### **Further notes.**

On some later rigs with MENU selections check these out in case various ones need to be set for rear socket use.  
On **TS-570S**, if using 13 pin rear socket. Set Menu # 33 AF IN to 0..... Set Menu # 34 AF OUT to 9.  
On **TS-870S**, if using 13 pin rear socket. Set Menu #20 PKT IN to 0..... Set Menu # 21 PKT OUT to 9.

On **FT-847**, it has been noted that if to high an audio transmit level is used. The PTT will drop out. The Audio in from computer be raised to obtain required 30/40 watts output, with regard to PTT staying on transmit

**YAESU FT-1000 RANGE. Some rigs in this range will not allow USB to be selected while in PKT mode and using the 5 Pin rear din. SELECT PKT on front panel.**

However this really is not a problem as PSK-31 BSPK is not sideband sensitive ,one side of QSO can be on USB while the other can be on LSB. Only in QSPK is there a need for both stations to be on the SAME sideband.

**YAESU FT-920 and 990** Check that **MENU 45** is set to No Offset.  
**ICOM 706MK11G** Set Menu 29 to 1200 speed and Menu 30 to OFF.  
**YAESU FT857** Set Mode to DIGI.

On some earlier rigs like **FT990 –FT920** they need to be switched to **PKT** on front panel for 5 Pin ACC ports to be active.  
If your rig is a recent design it may have a mode marked **DIGI**, this will need to be selected to bring rear port into use.

# TROUBLE SHOOTING NOTES FOR INTERFACING OF ISOTERM

It would appear from phone conversations I am having with various customers, that a number of people are not reading the instructions supplied either with the ISOTERM or the HELP file in DIGIPAN or other programs. I will attempt here to cover the common problems discussed.

## **IT WONT PUT RIG INTO TRANSMIT. I mean by this the PTT in not being triggered**

Check the **CONFIG file** in **DIGIPAN**. It will request that you select the COMs port you are wanting to use it also asks for you to select RTS or CTS switching. All ISOTERMs are wired for **RTS**. If you don't know what Coms port you are using. Select one at a time and try each one, to see if it will trigger rig into transmit. Also on later rigs with **PACKET** input socket, make sure you select **PACKET** on front panel.

## **ITS NOT RECEIVING.**

Again go to **CONFIG file**. Go to **WATERFALL DRIVE**. You will be presented with slider controls. These are Soundboard **LINE IN** controls. Make sure non are **MUTED**. Take all controls to **MAX** as you monitor the **WATERFALL**. Usual controls are marked **LINE IN**. Not all Soundboards are marked the same. So play around and check the operation on receive. Set slider for blue background with yellow specks. You should be able to see **PSK-31** signals as **YELLOW** streaks. Monitor 14.070 while looking to set up system. Unless band is closed there are usually a good number of signal around this frequency.

## **ITS NOT TRANSMITTING. I mean by this the PA meter on rig is not showing POWER OUT.**

Again go to **CONFIG file**. Select **Transmitter Drive**. Again you will see a set of Sliders controlling the soundboard **OUTPUT**. But don't forget, to have your mike control on the rig, at least in the position that would drive it for **SSB**. **ALSO THE ATTENUATION CONTROL IN THE ISOTERM IS FOR YOUR USE..** I can't set it here to suit all rigs. It has been set to suit **MY SETUP**. But differing positions of **your MIKE GAIN**. **SOUNDBOARD OUTPUT and ISOTERM ATTENUATOR** will all mean that my set-up will differ from yours.

One other test you can carry out.

Plug a set of headphones into the **LINE OUT** jack socket of your soundboard. Go into transmit on **DIGIPAN**, you should hear a tone in the headset. Play around with the **SLIDERS** to find which one turns volume up/down. Its usually **WAVE and OUTPUT** Reconnect the 3.5mm jack into your **LINE OUT** and check **PA** current shown on rig when you go to transmit. Set **PA** output for maybe 30/40 watts. This is sufficient power for **PSK-31**.

So just think what you are trying to achieve and work towards that goal. **One step at a time.**

With out exception all cases reporting that the **ISOTERM** is **NOT WORKING** have been no other than lack of reading the instructions. And ignoring the **DIGIPAN** help files.

**PSK-31** is a wonderful mode, just take time setting up your rig. By all means if you are having difficulties in getting going and you have checked out the above advice please do not hesitate to contact me

ISOTERM TRAVELLER DATA INTERFACE

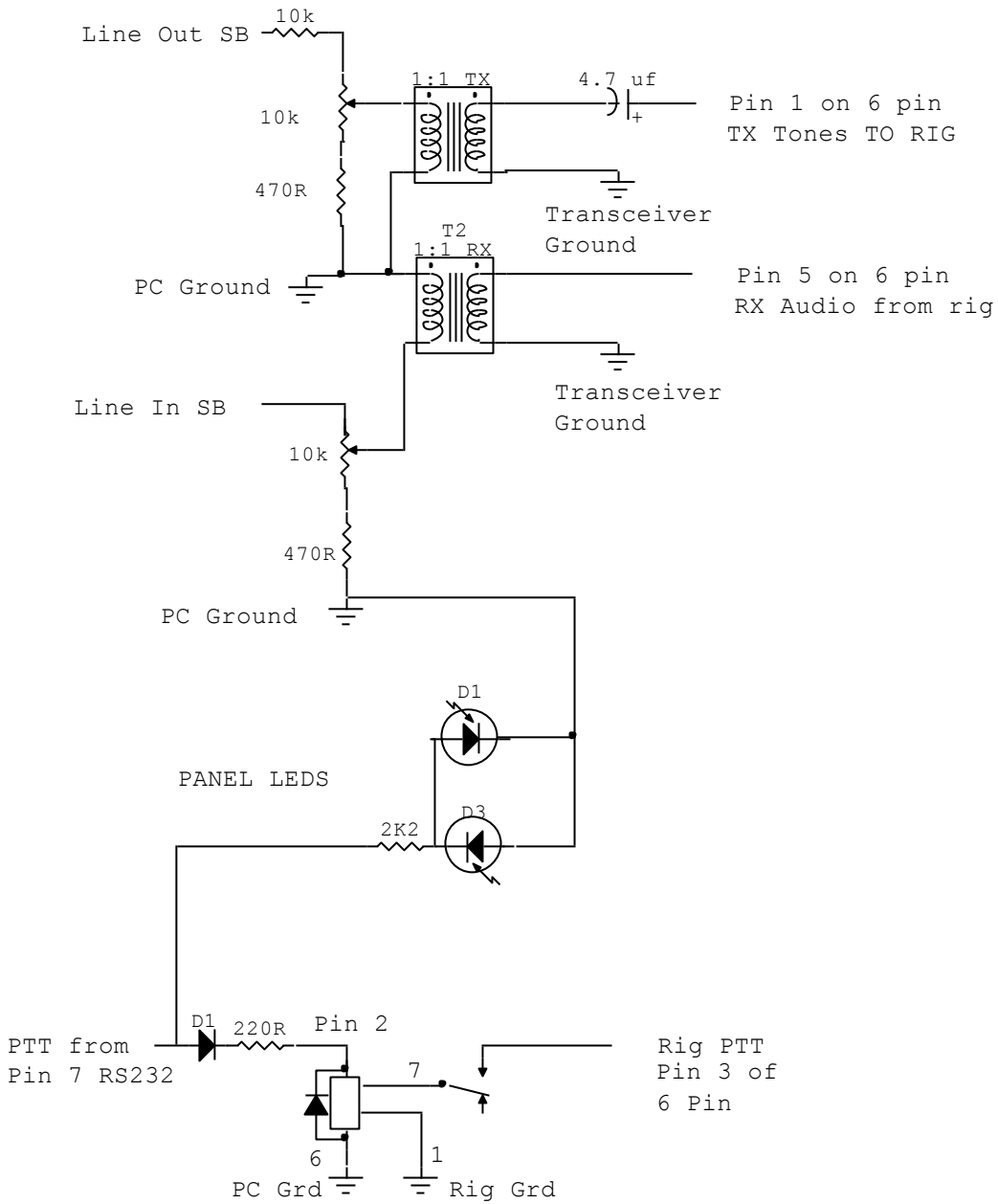

6 Pin Mini din rear connections

Computer RS-232

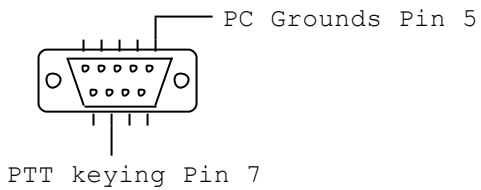

**SET UP NOTES as REQUIRED**